

GC050LX / GP050LX

CUSHION AND PNEUMATIC TIRE TRUCKS

5,000 lbs

STANDARD EQUIPMENT

- PSI 2.4L LPG engine
- 42" Class 2 fork carriage (GP050LX)
- 38.5" Class 2 fork carriage (GC050LX)
- 42" Standard taper pallet forks
- Load backrest - 48" high
- 5° forward / 5° back tilt
- Three (3) cowl mounted mechanical hydraulic control levers
- 3 function (1 aux.) hydraulic control valve
- Single pedal inch brake
- LPG tank bracket
- Anti-clog radiator
- U.L. Classification LPG
- Overhead guard 85" (2149mm)
- 12" steering wheel with wheel spinner knob
- Key switch start with anti-restart
- Forward / reverse direction lever
- Non-suspension vinyl seat
- Counterweight exhaust
- Low fuel indicator
- Continuous Stability System (CSS™)
- Integrated dashboard display
- Adjustable steering column
- Power steering
- Floor mat
- Operator restraint system
- Operator Presence System (OPS)
- Non-cinch seat belts
- Integral tie downs
- Operating manual
- 12 months / 2,000 hours manufacturer's warranty
- 24 months / 4,000 hours manufacturer's powertrain warranty

OPTIONAL EQUIPMENT

- PSI 2.4L dual fuel engine (GP050LX)
- 42" wide integral sideshifter (GP050LX)
- 38.5" wide integral sideshifter (GC050LX)
- 48" long forks
- 81" MFH truckers mast (GC050LX)
- 23 x 10 x 12 wide pneumatic shaped solid drive tires (GP050LX)
- Pneumatic-shaped solid drive and steer tires (GP050LX)
- Non-marking pneumatic-shaped solid drive and steer tires (GP050LX)
- Non-marking solid drive and steer tires (GC050LX)
- Audible reverse activated self adjusting alarm 82-102 dB(A)
- Full-suspension vinyl seat
- Visible amber strobe light - continuous activated, overhead guard mounting
- Halogen or LED front and rear work lights
- Halogen or LED front and rear work lights with LED brake/tail/backup lights
- Dual side view mirrors
- 2.5 lb. fire extinguisher
- Rear drive handle with horn button
- Additional height triplex masts
- Four (4) cowl mounted mechanical hydraulic control levers for non-clamping attachments
- 4 function (2 aux.) hydraulic control valve
- 3 function (1 aux.) hose group
- 4 function (2 aux.) hose group
- Attachment extension tubes with or without quick disconnects
- Traction speed limiter



GC050LX

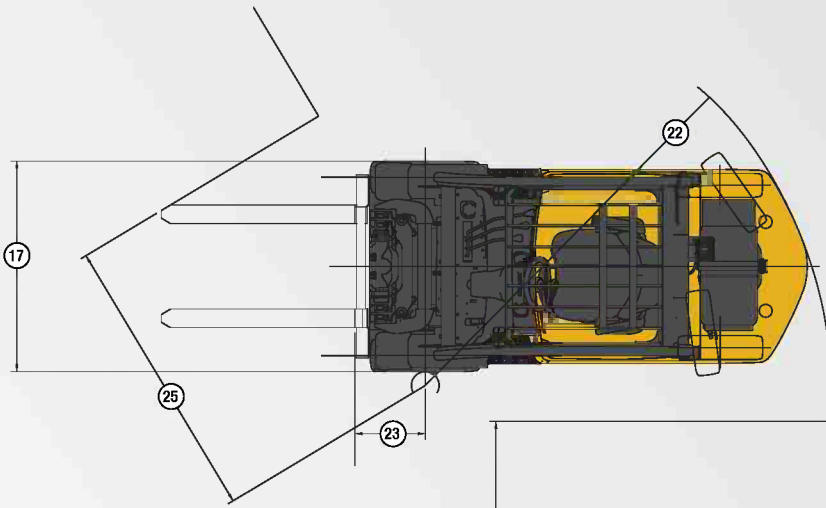
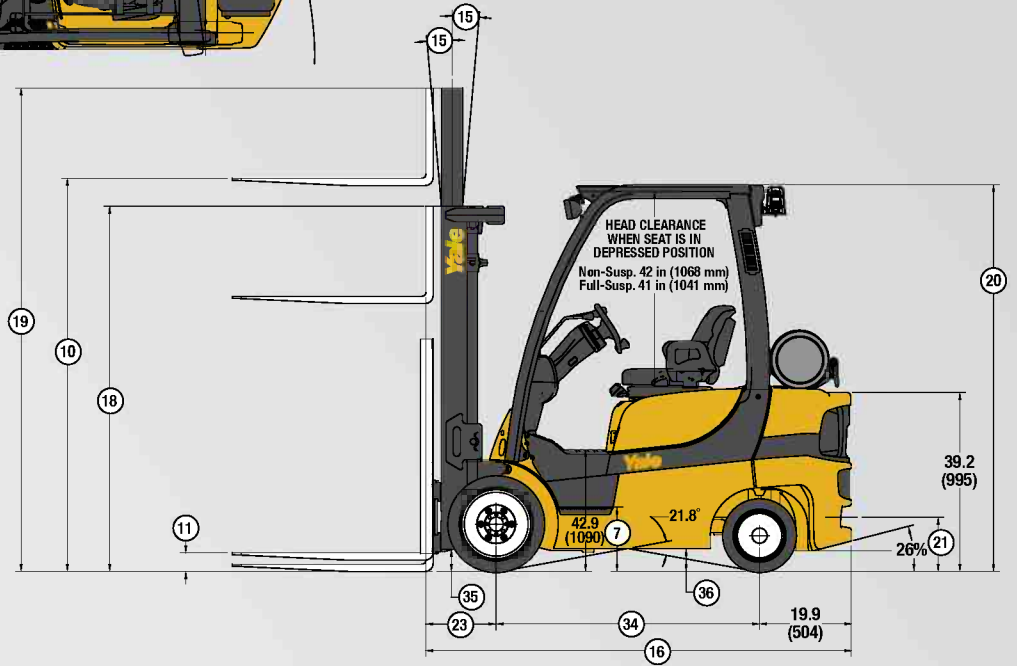
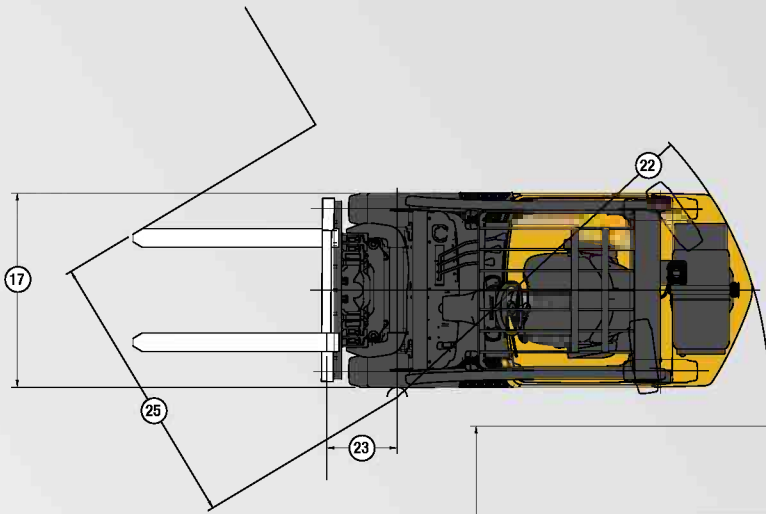

GP050LX

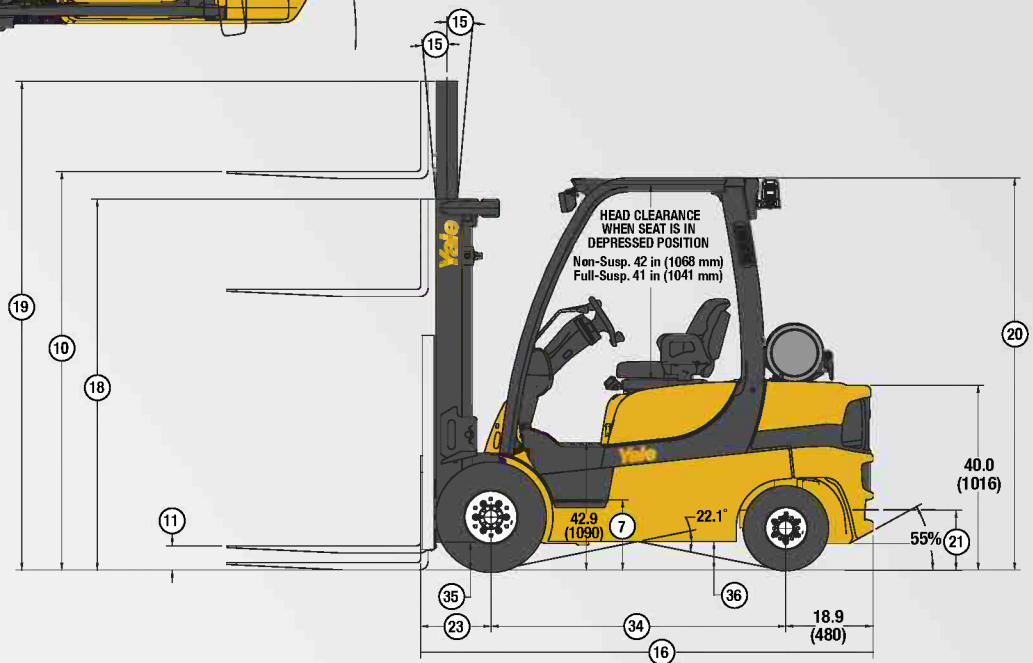

GENERAL	1	Manufacturer Name		Yale	Yale
	2	Model		GC050LX	GP050LX
		Transmission Type		Elec. Controlled Powershift	Elec. Controlled Powershift
		Engine		PSI 2.4L	PSI 2.4L
		Brake System		Drum Brakes	Drum Brakes
	3	Rated Capacity	lb (kg)	5000 (2268)	5000 (2268)
	4	Load Center	in (mm)	24 (610)	24 (610)
	5	Drive Power Type		LPG	LPG Dual Fuel
DIMENSIONS	6	Operator Type		Seated Rider	Seated Rider
	7	Step Height	in (mm)	13.6 (345)	14.0 (356)
	8	Tire Type - Pneumatic, Cushion		Cushion	Pneumatic
	9	Number of Wheels, front/rear (X = driven)		2x/2	2x/2
	10	Lift Height, Top of Fork (TOF)	in (mm)	170 (4325)	170 (4325)
	11	Free Lift with LBR (TOF)	in (mm)	32 (823)	32 (837)
		Free Lift without LBR (TOF)	in (mm)	60 (1540)	61 (1554)
	12	Standard Carriage Width	in (mm)	38.5 (977)	42 (1067)
	13	Fork Dimensions, Thickness x Width x Length	in (mm)	1.6x3.9x42 (40x100x1067)	1.6x3.9x42 (40x100x1067)
	14	Fork Spacing - Std Carriage - Max. Outside to Outside Edge	in (mm)	33.5 (852)	33.5 (852)
		Fork Spacing -Std Carriage - Min. Inside to Inside Edge	in (mm)	6.2 (158)	6.2 (158)
	15	Mast Tilt, forward/back	degrees	5/5	5/5
	16	Overall Length (length to face of forks)	in (mm)	92.2 (2341)	98.1 (2491)
	17	Overall Width	in (mm)	42.0 (1068)	45.7 (1160)
	18	Height of Standard Mast, lowered	in (mm)	81 (2035)	81 (2049)
	19	Height of Standard Mast, extended with LBR	in (mm)	218 (5537)	218 (5537)
		Height of Standard Mast, extended without LBR	in (mm)	190 (4820)	190 (4820)
	20	Height to Top of Standard Overhead Guard (high)	in (mm)	85 (2136)	85 (2149)
	21	Towing Coupling Height (pin type)	in (mm)	12.2 (309)	13.0 (330)
	22	Outer Turning Radius	in (mm)	81.2 (2062)	88.0 (2236)
		Inner Turning Radius	in (mm)	3.0 (75)	4.1 (103)
	23	Load Distance (load face-ctr of wheel to face of forks - front overhang)	in (mm)	15.3 (388)	15.3 (388)
	24	Aisle Width, right angle stack (add length of load)	in (mm)	96.5 (2450)	103.3 (2624)
	25	Equal Aisle, 90° intersecting aisle (w/ pallet W=42in, L=48in)	in (mm)	76.0 (1930)	79.9 (2030)
GRADEABILITY	26	Travel Speed (RL/NL)	mph (km/hr)	11.3/11.4 (18.2/18.4)	11.6/11.8 (18.7/19.0)
	27	Lifting Speed, 2 Stage LFL (RL/NL)	ft/min (m/sec)	124/128 (.63/.65)	124/128 (.63/.65)
		Lifting Speed, 3 Stage FFL (RL/NL)	ft/min (m/sec)	116/120 (.59/.61)	116/120 (.59/.61)
	28	Lowering Speed, 3 Stage FFL (RL/NL)	ft/min (m/sec)	96/83 (.49/.42)	96/83 (.49/.42)
	29	Drawbar Pull @ 1.0 mph or 1.6 km/h (RL/NL)	lbs (kg)	3020/1676 (1370/760)	3243/2068 (1471/938)
	30	Gradeability, maximum (RL, NL)	%	30/22	31/28
	Gradeability @ 1.0 mph or 1.6 km/h (RL/NL)	%	25/22	27/28	
WT.	31	Unladen Weight (w/ std equipment: mast, carriage, forks, etc.)	lb (kg)	7928 (3596)	7398 (3356)
	32	Axle Loading Unladen w/ std option configuration (Front/Rear)	lb (kg)	3115/4812 (1413/2183)	3186/4212 (1445/1911)
		Axle Loading Laden w/ std option configuration (Front/Rear)	lb (kg)	11559/1369 (5243/621)	11262/1136 (5108/515)
WHEELS & TIRES	33	Tire Size, front		21x7x15	6.5x10-10
		Tire Size, rear		16x5x10.5	5x8
	34	Wheelbase	in (mm)	57.1 (1450)	63.9 (1623)
	35	Ground Clearance, under mast laden	in (mm)	3.4 (87)	3.9 (98)
	36	Ground Clearance, center of wheelbase	in (mm)	4.6 (116)	5.0 (127)
	37	Brakes Service - Method of Control/Operation		Hydraulic/Foot	Hydraulic/Foot
	38	Brakes Park - Method of Control/Operation		Mechanical/Hand	Mechanical/Hand
	39	Battery Type		Maintenance Free	Maintenance Free
POWERTRAIN	40	Battery Volts/Cold Cranking Amps		12V/475	12V/475
	41	Engine Manufacturer		PSI 2.4L	PSI 2.4L
	42	Engine Output, in accordance with ISO1585	hp (kw)	44 (33) @ 2550 RPM	44 (33) @ 2550 RPM
	43	Torque	ft-lb (N-m)	118 (160) @ 1200 RPM	118 (160) @ 1200 RPM
	44	Number of Cylinders/Displacement	No./cc (ci)	4/2351 (143)	4/2351 (143)
	45	Gear Change Type		Powershift	Powershift
	46	Transmission, number of speeds forward/reverse		1F/1R	1F/1R
	47	Working Pressure for Attachments	psi (bar)	2306 (159)	2306 (159)
	48	Hydraulic Tank - Capacity (drain & refill)	gal (liters)	7.9 (29.9)	10.4 (39.4)

GC050LX MAST DIMENSIONS

	Overall Height		Free Fork Height without LBR		Max Fork Height		Extended Height with LBR		Tilt
	in	mm	in	mm	in	mm	in	mm	fwd/back
2-Stage Limited Free Lift (LFL) Mast									
Opt	62	1550	5	140	81	2072	130	3295	5/5
3-Stage Full Free Lift (FFL) Mast									
Std	81	2035	60	1540	170	4325	218	5537	5/5
Opt	87	2135	66	1690	187	4775	236	5987	5/5
Opt	90	2285	70	1790	199	5075	248	6287	5/5

GP050LX MAST DIMENSIONS

	Overall Height		Free Fork Height without LBR		Max Fork Height		Extended Height with LBR		Tilt
	in	mm	in	mm	in	mm	in	mm	fwd/back
3-Stage Full Free Lift (FFL) Mast									
Std	81	2049	61	1554	170	4325	218	5537	5/5
Opt	87	2199	67	1704	187	4775	236	5987	5/5
Opt	91	2299	71	1084	199	5075	248	6287	5/5



YALE MATERIALS HANDLING CORPORATION

P.O. Box 7367, Greenville, NC 27835-7367

www.yale.com

Yale is a Registered Trademark and  is a Registered Copyright.
©Yale Materials Handling Corporation 2014. All Rights Reserved.

Manufactured in our own ISO 9001 and 14001 Registered Facilities

2223-1B 1/2015 All trucks shown with optional equipment.

Truck performance may be affected by the condition of the vehicle, how it is equipped and the application. Consult your Yale® Industrial Truck Dealer if any of the information shown is critical to your application. Specifications are subject to change without notice.

This truck meets all applicable mandatory requirements of ANSI B56.1 Safety Standard for Powered Industrial Trucks at the time of manufacture. Classified by Underwriters' Laboratories, Inc., as to fire and electric shock hazard only for Type E industrial trucks.

The Yale® products included in this document may be covered by US patent 6,684,148 and other patents pending.